

After use

Storage and maintenance: when the unit is to be stored for a long period, remove the power supply and bit, open the carbon brush cover and blow out any accumulated carbon brush dust with compressed air, and wipe the exterior clean. Then store the screwdriver carefully in a dry, dust-free place away from direct sunlight. Store the bit in grease. To ensure continued serviceability, periodically check and maintain the screwdriver.

Serial No.:

Troubleshooting

If the screwdriver does not work properly, check the list below. If you cannot solve the problem do not open the unit. Contact one of our authorized agents as soon as possible.

If the screwdriver does not run

Check that the power supply is outputting power.

- Check that the power supply plug is inserted properly and that output plug terminals No.1 (-) and NO.4 (+) show 30VDC (approximate) between them. If no output is shown, change the power supply.

- Check for an open or short circuit in the 5p-5p or 6p-6p cord connecting the screwdriver to the power supply.

- If an open or short circuit is found change the cord or plug. (use plug type 2G2021(5p) or 2G2022(6p) or purchase equivalent type)

- check that the fuse is intact. Caution: when changing the fuse, unplug the power supply.

check that the carbon brush is undamaged, that the carbon brush guide cord with the rotor to become too small. Anyone of these factors could cause the screwdriver to stop rotating or rotate abnormally.

Inspection method: open the carbon brush cover and use a non-conductive insulated rod to gently press the brush. If the screwdriver resumes rotating, the carbon brush has reached the end of its useful life and must be replaced immediately.

Check that the rotation direction switch are working properly. If no 'click' is heard when a trigger is depressed, it is not working and must be replaced.

(make sure to perform this check in a quiet place)

If the screwdriver is not rotating normally

There is a protective circuit within the power supply. Power is only supplied normally from 3 to 5 seconds after current flow begins.

If the motor only runs intermittently during 'Forward' operation, try 'Reverse' operation, or rotate the anvil 90 degrees until a 'click' is heard, then re-attempt 'Forward' operation.

Long-term use causes the motor's commutator to wear down. In this case, it must be replaced. (this repair must be performed by one of our authorized agents)

If the bit falls out easily or wobbles

check that the bit matches our specifications. If not, change the bit to one that does.

If the bit tends to wobble, remove the bit, rotate it 60 or 180 degrees and re-insert it.

If the screwdriver does not stop when the selected torque is reached

An excessive torque setting can cause the screw to strip the threads, with the result that the clutch does not activate. Lower the torque to a level that does not cause stripping.

Differences in size between the bit tip and screw slot lengths can cause stopping. Change to a suitable bit tip.

The brake circuit may be damaged or the sensor switch may have shifted.

(this repair must be performed by one of our authorized agents)

Warranty

We provide a one-year free repair service warranty with this product. The warranty is good for one year from the date of purchase entered on the Product Information Form. The retailer's stamp must appear on the form to confirm the date. However, the following circumstances we will charge the user for any parts and labor cost associated with repairs.

For repairs involving normal wear to parts including carbon brushes, bits and power cord, and also to the exterior surface.

If the screwdriver was connected to a power source of the incorrect voltage.

If there was inappropriate use or an attempt to repair the unit by the user.

After the period of the guarantee, or if the user cannot present the manual with stamped Product Informatio.

Retailer's Stamp

Specifications and design may be changed without notice for improvement (A-4)

ASA Industrial Electric Screwdriver User's Manual
(for full-automatic models – low volt. DC motor with controller)

A Word of Thanks to Our Customers

Thank you for choosing lightweight and powerful electric screwdrivers. In order to insure maximum performance and product life, please read through this manual before using your screwdriver.

Feature

Our screwdrivers are designed for use with precision torque locking screws. It can be used for assembly of large range items such as home appliances, computers furniture and car industry etc.

Low vibration, low noise, meets environmental protection demands.

Low-voltage electronic braking circuit for precision torque control, low breakdown rate and long product life.

Low-voltage DC motor for safety and prevention of electric shocks.

Design features separation of screwdriver and control for low repair costs and higher serviceability rate.

Switching power supply plugs directly into screwdriver and supplies stable voltage, provides more accurate torque and longer motor life.

Right-angel (90°) head adapter attaches easily to screwdriver for use in small spaces (>60mm), operates smoothly. (Optional)

Screwdriver can be provided with a pistol grip for added safety and convenience. (Optional)

Ergonomically designed exterior reduces work fatigue and increases productivity.

Specifications

Model	7000	7000S	7500	7500PS	8000	8000S	8500	8500S	9000	9000S
	7000PS	7000S(PS)			8000PS	8000S(PS)	8500PS	8500S(PS)	9000PS	9000S(PS)
Power source	30VDC									
Torgue range Kgf-cm / lbf-in	7-20 / 6.1-17.4		7-30 / 6.1-26.0		12-30 / 10.4-26.0		12.0-40.0 / 10.4-34.7		20.0-50.0/17.3-43.4	
Torque accuracy	±3%									
No load speed/ rpm	700	1000	1000	550	1000	700	1000	500	650	
Torque setting	Stepless									
Available Screw	Machine screw mm / in	3.0-4.0 / 0.12-0.16		3.0-5.0 / 0.12-0.20		3.5-5.0 / 0.14-0.20		3.5-5.5 / 0.14-0.22		4.0-6.0/0.16-0.24
	Machine screw mm / in	2.6-3.5 / 0.10-0.14		2.6-4.0 / 0.10-0.16		3.0-4.0 / 0.12-0.16		3.0-4.5 / 0.12-0.18		3.5-5.0/0.14-0.20
Weight g / lb	670 / 1.47 , 740/1.6 (PS)									
Length mm / in	265 / 10.4, 269/10.6 (PS)									
Available bit shank	5 φ /5mm hex shank · 1/4" hex shank									
Power consumption	60									
Available power supply	APS-30,APT70(5P)(ASA-7000/8000) · APS-30U,APS-70S(6P)(ASA-7500/8500/9000)									
Clutch impact	Just one time when torque up									

Outline (this drawing applies only to 1/4" hex. bit shank screwdrivers)

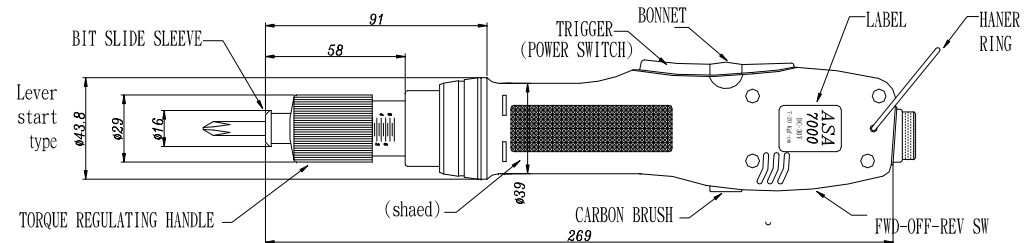

Accessories

This product comes supplied with a pair of carbon brush and two bits.

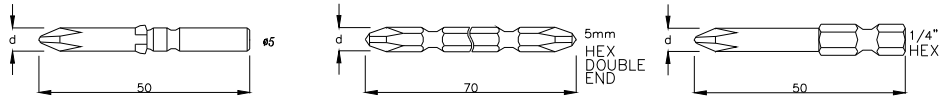

Bits(one set per screwdriver)

Bit specifications									Available Screwdriver Model
φ 5			5mm Hex shank(PS series)			1/4" Hex shank			
Tip No.	Tip Dia d	P#	Tip No.	Tip Dia d	P#	Tip No.	Tip Dia d	P#	
#1	5 φ	7W3844	#1	5mm	7W5848	#1	φ 4.5	7W6744	ASA-7000/PS
#2	5 φ	7W3864	#2	5mm	7W5868	#2	φ 6.0	7W6964	ASA-7000S/(PS)
#2	5 φ	7W3864	#2	5mm	7W5868	#2	φ 4.5	7W6764	ASA-7500/PS
#2	5 φ	7W3864	#2	5mm	7W5868	#2	φ 6.0	7W6964	ASA-8000/S
---	---	---	---	---	---	#2	φ 6.0	7W6964	ASA-8000S(PS)
---	---	---	---	---	---	#2	φ 6.0	7W6964	ASA-8500/PS
---	---	---	---	---	---	#2	φ 6.0	7W6964	ASA-8500S/(PS)
---	---	---	---	---	---	#2	φ 6.0	7W6964	ASA-9000/S
---	---	---	---	---	---	#2	φ 6.0	7W6964	ASA-9000S/(PS)

Power supply(optional)

Model	Dimension mm			Operation volt (AC)	Output volt (DC)	Weight (g/lb)	Approval	Available Model	Packing
	L	W	H						
APS-30	154	84	52	100-120V	30V/5P (constant)	620/1.36	UL,cUL,CE	ASA-7000 ASA-8000	Together With Driver
				220-240V					
APS-30U	154	84	52	110-120V	30V/6P (constant)	620/1.36	Pending	ASA-7500	Separated From Driver
				220-240V					
APT-70	220	118	96	115V	30V/5P	3700/8.1	UL,cUL,CE	ASA-7000 ASA-8000	Separated From Driver
				230V					
APT-70S	220	118	96	115V	30V/6P	3700/8.1	Pending	ASA-7500 ASA-8500 ASA-9000	Separated From Driver
				230V					

- APS-35A/APS-35E are switching circuit power supplies. They are light and small, consume little electricity and supply stabile voltage.
- Stabilizer accessories : 2 locking ties, 2 pieces of double-sides tape(only for APS-35A/APS-35E)

Before use, read the following

- Use the correct voltage: Carefully check the voltage shown on the power supply and this manual and determine the correct voltage. Only plug the unit into a power source of the correct voltage.
- Determine the appropriate torque range: choose the correct screwdriver for the torque you will require. To lengthen product life, avoid long-term high torque use.
- Make sure the screwdriver is undamaged: If the power code is scraped or damaged, it should be immediately unplugged and replaced to avoid electric shocks or a short circuit that could result in fire.
- Use in an appropriate work environment: To ensure safety, do not use in high temperature, high humidity environments or near flammable materials. Keep the power cord away from tools or equipment that might scrape or melt it.
- When plugging in or unplugging the power cord, hold the plug firmly. Never pull on the cord.

Method of operation and important points

- Brace fastened objects securely-Before operation, refer to "torque settings" item to determine the appropriate torque , and adjust the screwdriver to the appropriate torque. Make sure that the fastend objects are securely braced, and then begin operation. This procedure will avoid hazardous rapid rotation of the fastened objects due to excessive torque or insufficient bracing.

- Driving and removing screw: Before operation, set forward/reverse switch properly. To drive a screw, set the switch to the forward(FOR) position. To remove a screw, set it to the reverse(REV) position. Press the screwdriver onto the screw perpendicularly to being operation. Note: Don't operate the FWD/REV switch when the motor is running.

- Torque settings: Use the regulating handle or torque reaction ring (ASA-8500, 9000 only) to set the torque. Turning it in a clockwise direction into the screwdriver will increase the torque. Turning it counterclockwise out of the screwdriver will decrease the torque. Note: The engraved markings on the engraving ring are for reference only and do not indicate torque output. Torque output can only be determined by repeated testing with a torque meter or hand-held spanner torque meter. To prevent your torque setting from being changed, we can provide a torque cover (optional) which covers and secures the regulating handle.

- Bit insertion: Use your finger to depress the slide sleeve into the screwdriver and insert an appropriate bit. When the slide sleeve is released, the bit will be automatically engaged. Note: Do not hammer the bit in or pull it out forcibly.

- Secure screwdriver during operation: During operation, hang the screwdriver up securely (as from balancer) in order to prevent it from being knocked down and suffering external cracking, internal damage, or a snapped power cord.

- Start and stop: For lever start type. The motor begins running when the lever is depressed and stops when it is released. For push to start type. When the screwdriver is pressed onto a screw perpendicularly, inwards pressure from the screwdriver bit engages the power switch, and the motor begins running. When the pressure on the screwdriver is released, the bit and power switch revert to their original positions and the motor stops running.

- When the selected torque is reached: This product features an internal clutch assembly. When a screw is driven and the selected torque is reached, the clutch assembly will automatically disengage and a 'click' will be heard. At this point, even if the 'trigger'lever or depress force is not released, the power to the motor will be automatically cut off. Note: When driving screw, grasp the screwdriver firmly in order to prevent upwards recoil generated by the clutch release from forcing the screwdriver bit edge form the screw slot and damaging slot.

- When removing screws: when a previously driven screw cannot be removed using the same torque that it was driven with, raise the torque setting. After the screw is removed, return the regulating handle to its original setting. To simplify this operation, note the number 'click' sounds generated as the regulating handle is turned. When removing a screw, if the required torque is higher than the screwdriver's output torque, the clutch may not disengage, causing the user's hand and arm to be twisted. In this case immediately set the forward/reverse switch to "STOP" to cut the motor power and prevent injury.

- Operational frequency: suggest the operational frequency 1/4"(ON/OFF)second, the total screws 7000pcs/8hours, don't over our operational frequency suggest, and avoid the inside parts of screwdriver serious damage. If everyday work 8hours upward, please use two screwdriver by turns, protect the life of screwdrivers.

- Changing the carbon brush: Open the carbon brush cover by turning it counterclockwise with a coin or standard screwdriver(width5-7mm.)Remove the used carbon brush and insert a new carbon brush of the same specifications in the empty space. To complete the operation, close the carbon brush cover tightly by turning it clockwise. Then remove the carbon brush fastener

Note:

- When changing the carbon brush first unplug the screwdriver. Use a factory specification carbon brush.
- The notch on the carbon brush surface must face into the direction of the rotor rotation

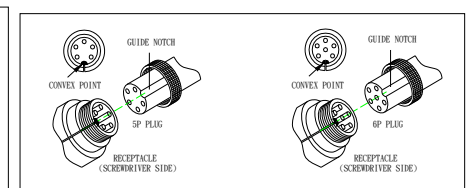
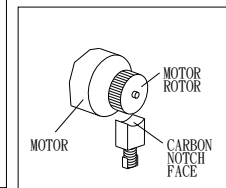
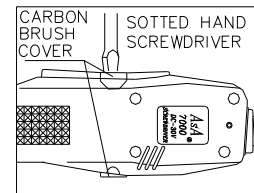

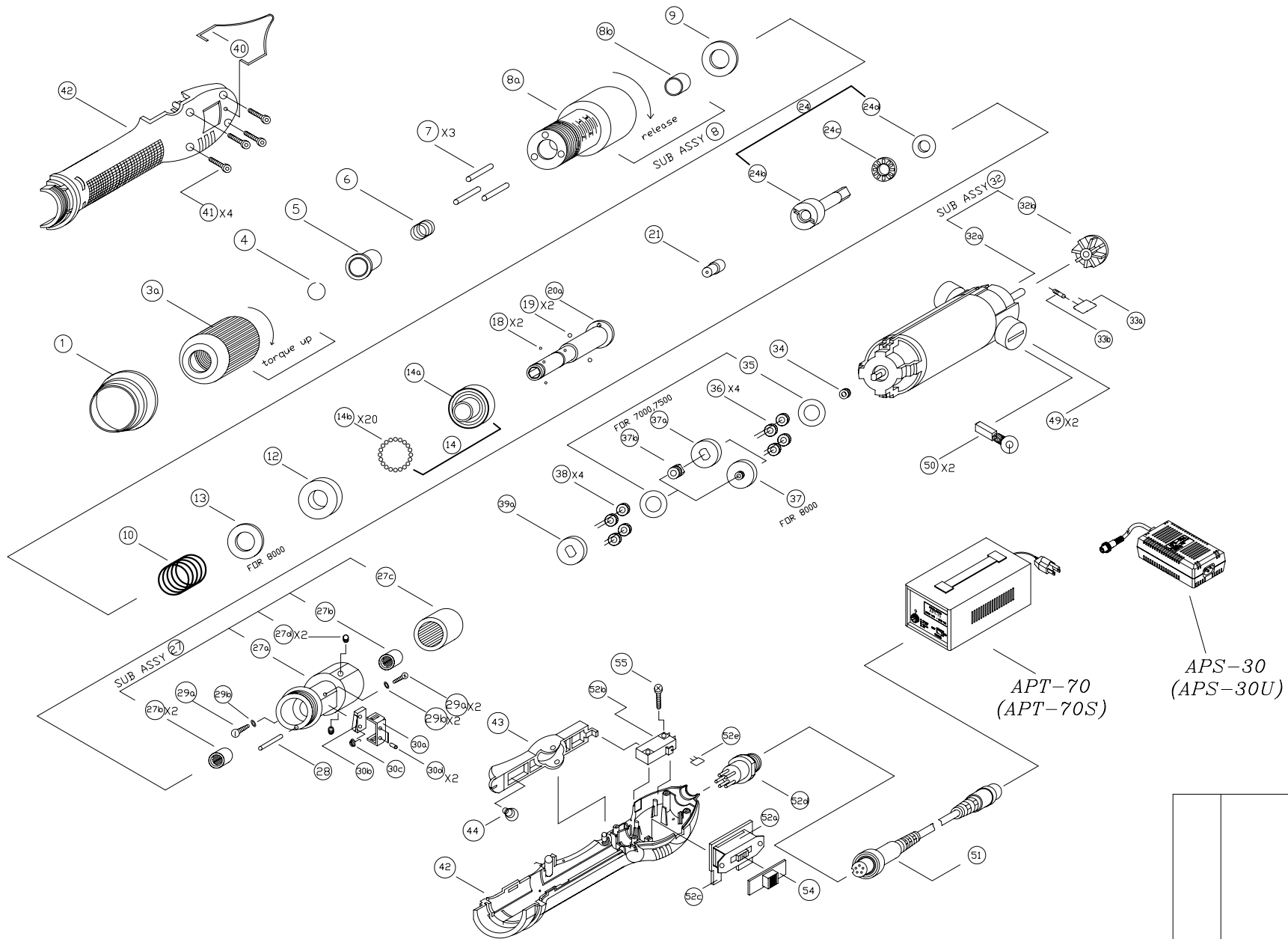

UNIT: M/M	DATE	NAME	NAME ASA- 7000, 7500, 8000 disassemble graphic	△	REVISED	12. 25' 06	L. I. C
DESIGN	2006. 03. 16	J. J. Y		SYM	DESCRIPTION	DATE	SIGN
DRAWN			AsA	ENTERPRISE CORP.			
CHECKED			TEL: (02)8751-0022(10 Line)				
APPROVED	2005. 04. 01	T. Ke	DWG. NO: M10035				

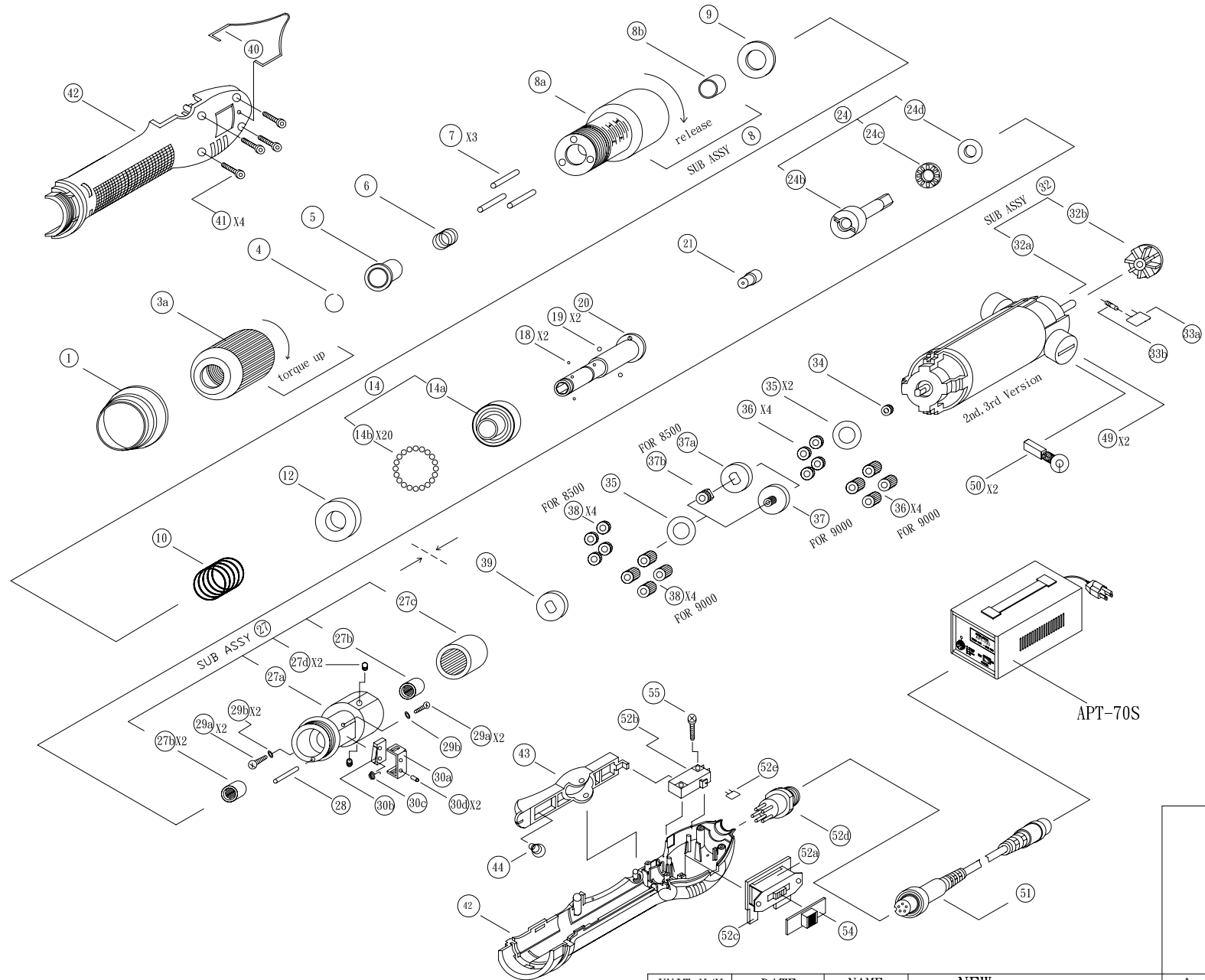

UNIT: M/M	DATE	NAME	NAME NEW
DESIGN			ASA- 8500, 9000
DRAWN	2005. 06. 01	J. J. Y	disassemble graphic
CHECKED			AsA ENTERPRISE CORP.
APPROVED	2005. 04. 01	T. Ke	TEL: (02)8751-0022(10 Line)

△	REVISED	01. 24' 07	L. I. C
SYM	DESCRIPTION	DATE	SIGN

DWG. NO: M10011

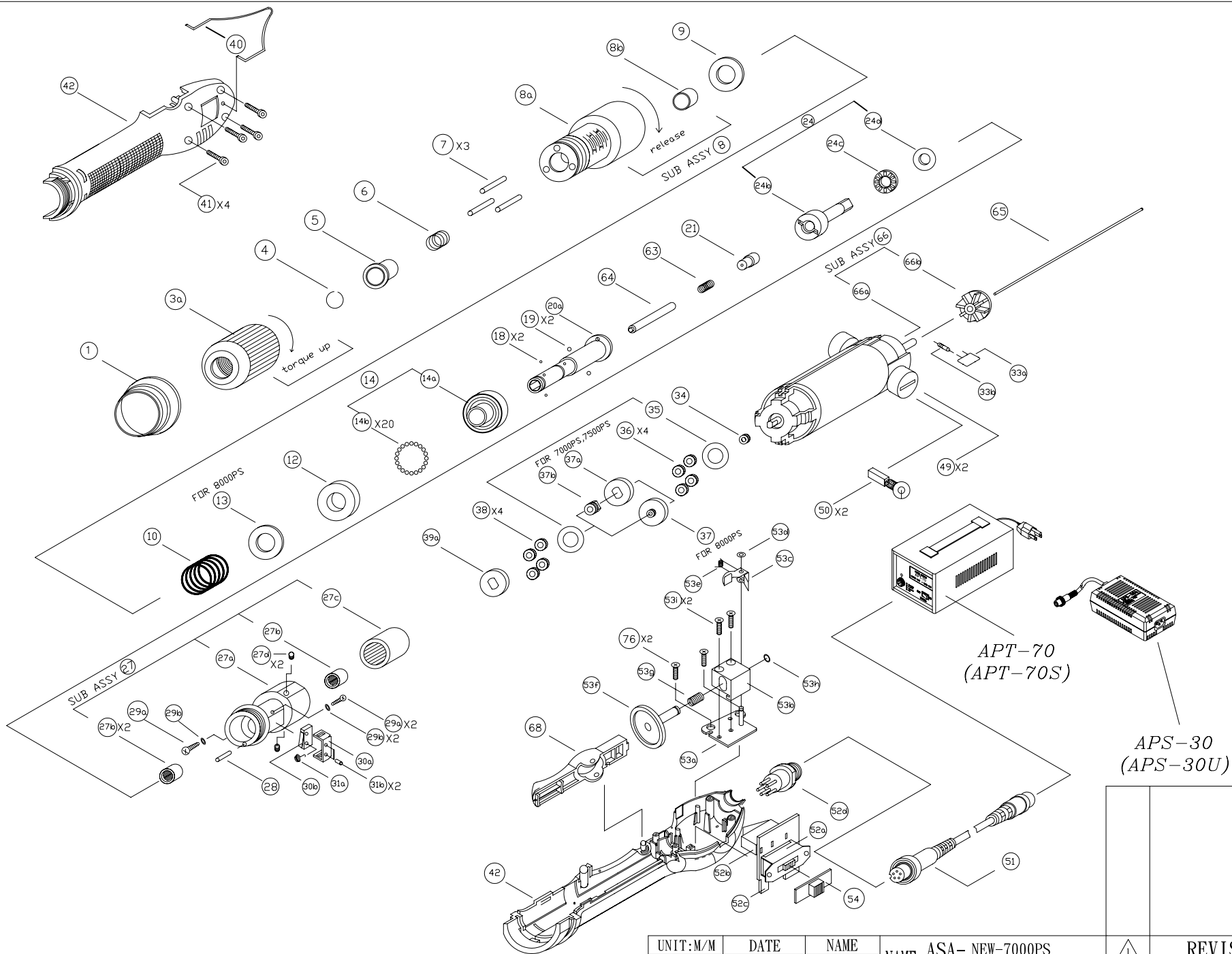

UNIT: M/M	DATE	NAME
DESIGN		
DRAWN	2006.03.16	C. C. Y
CHECKED		
APPROVED	2001.12.03	T. Ke

NAME ASA- NEW-7000PS
 7500PS, 8000PS
 disassemble graphic
ASA ENTERPRISE CORP.
 TEL: (02)8751-0022(10 Line)

△	REVISED	01.09'07	L. I. C
SYM	DESCRIPTION	DATE	SIGN

DWG. NO: M10036

APT-70S

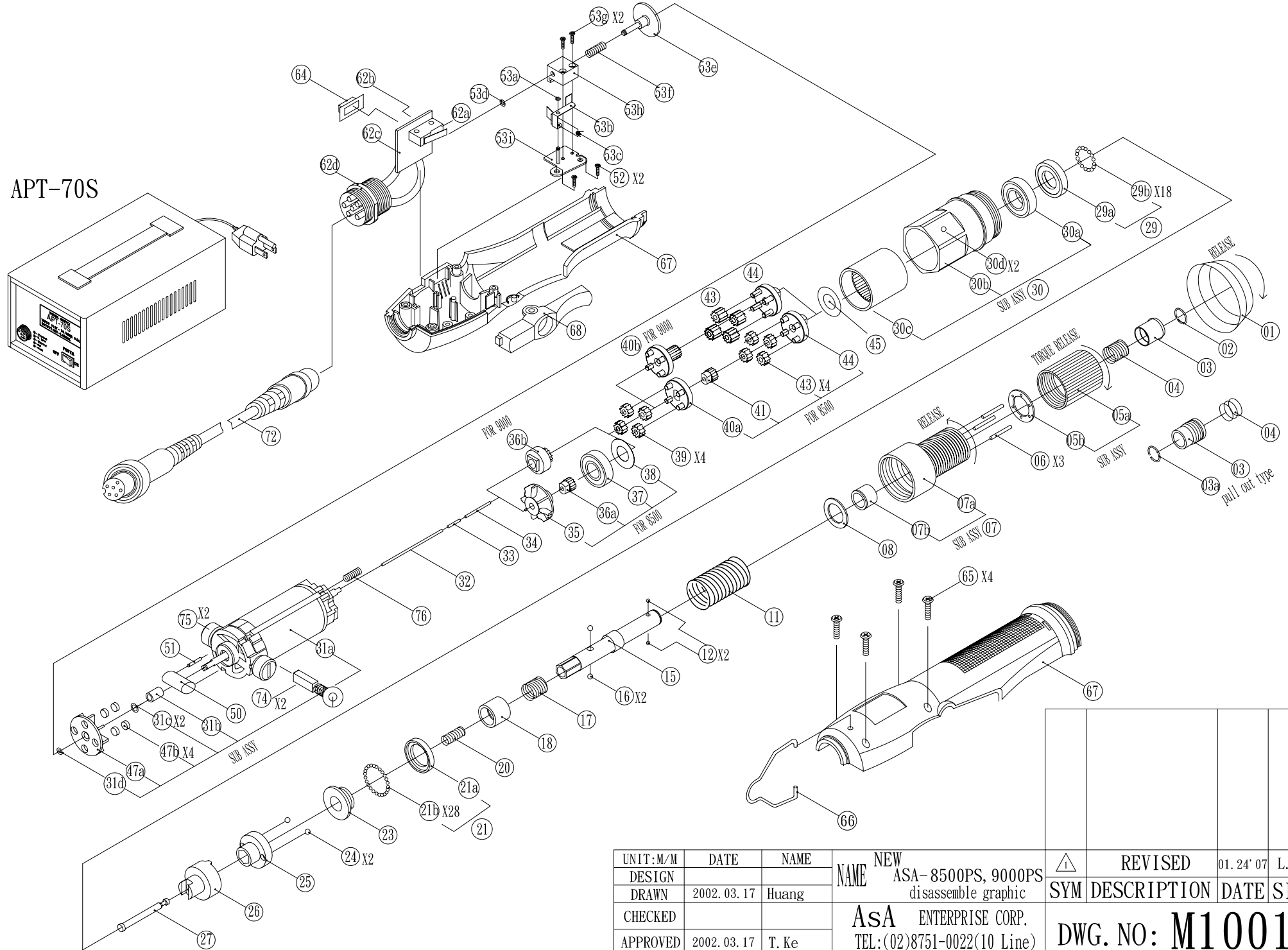

UNIT: M/M	DATE	NAME	NEW	REVISION	DATE	SIGN
DESIGN			NAME	ASA-8500PS, 9000PS	01.24'07	L. I. C
DRAWN	2002.03.17	Huang		disassemble graphic		
CHECKED			Asa	ENTERPRISE CORP.		
APPROVED	2002.03.17	T. Ke		TEL: (02)8751-0022(10 Line)		
				DWG. NO: M10012		